

BABY

VULCANO StarGold

PESO: kg 327

CONTENUTO D'ACQUA: litri 116

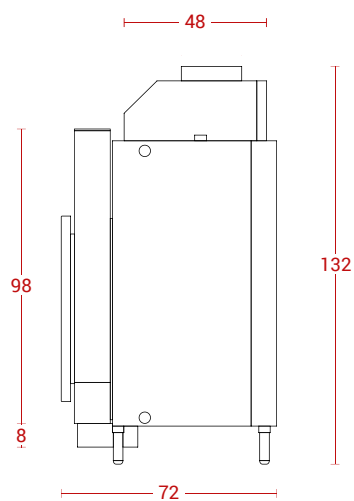

**VULCANO StarGold
BABY 1**

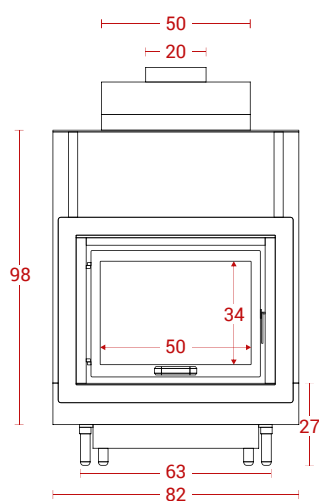

**VULCANO StarGold
BABY 2**

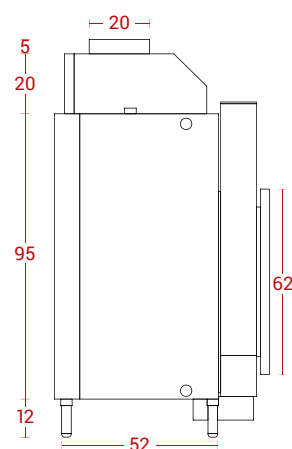

**VULCANO StarGold
BABY 3**

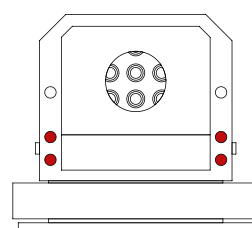
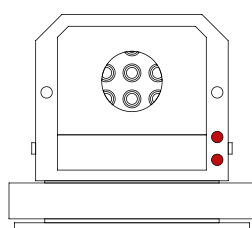
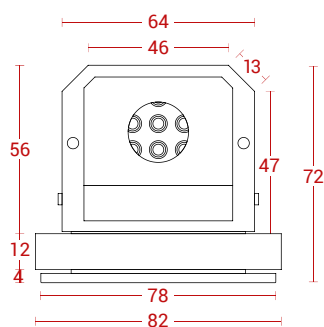

POTENZA TERMICA NOMINALE	RENDIMENTO	CLASSIFICAZIONE AMBIENTALE	CONTO TERMICO	CLASSE ENERGETICA
kW 22	88,1%	★★★★	Premialità 1,5	A ⁺